

TPA

Intensive Scourer

Performs an intensive cleaning of the grain kernel surface. Strong motor dynamically balanced with special rubbing beaters and paddles for product advancement. The retention time of the product inside the machine is regulated by means of an air division screen system. Built-in fan for cleaning of the rotor and the sieve



TPA 35-135

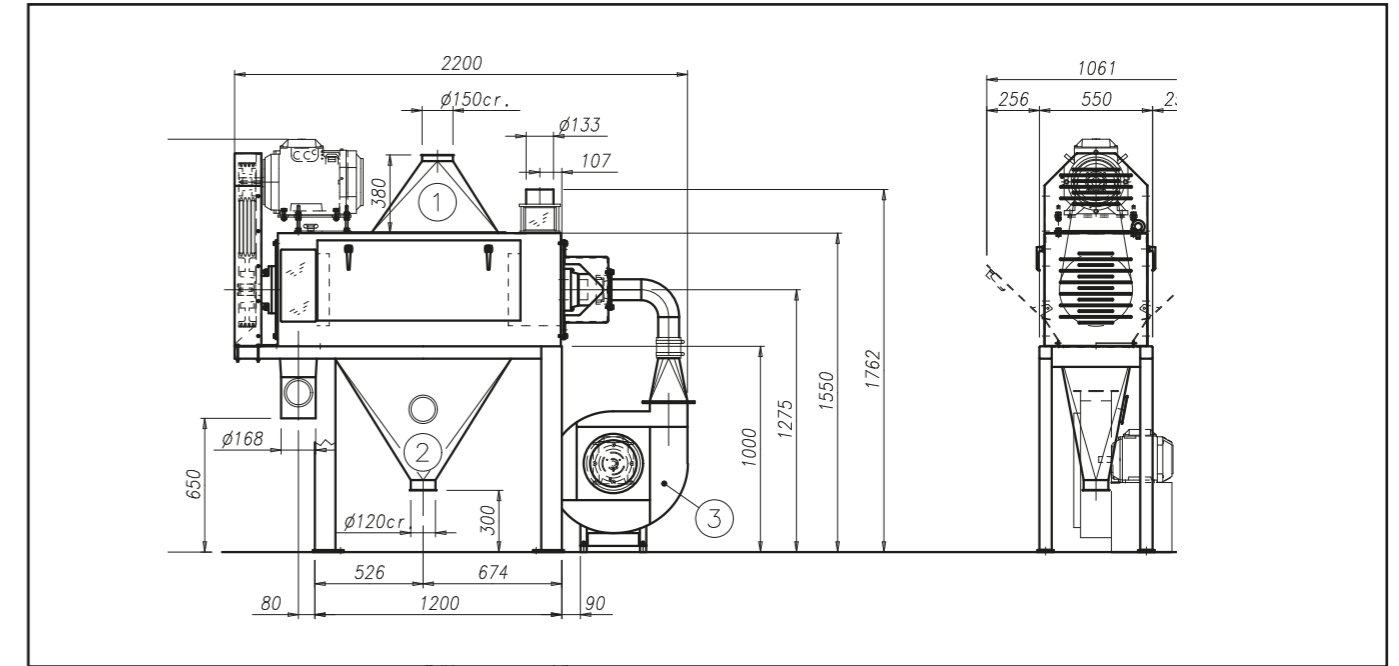

TPA 50-165

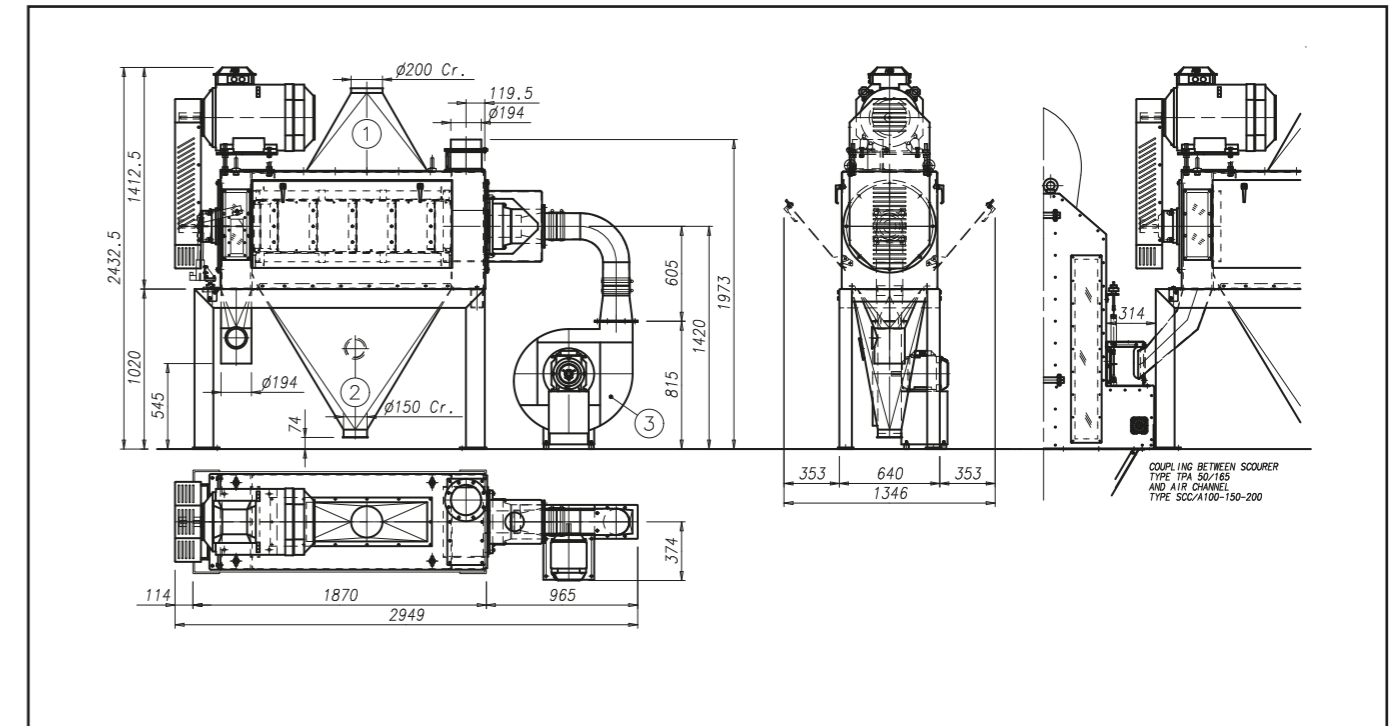

Type	*Capacity t/h	Power Kw	Aspiration 1 m ³ /min mmH2O		Aspiration 2 m ³ /min mmH2O		Fan 3 Kw m ³ /min		Weight Kg	Volume m ³
TPA 35-135	8	15	10	50	15	50	3	25	660	3
TPA 50-165	10	22	30	50	10	50	4	35	1200	5
	15	37								
	20	45								

* Soft wheat 0,75t/m³
Units = mm