

FRESH PASTA

**Pavan**  
PASTA AND EXTRUDING TECHNOLOGIES

# MRD 540

SINGLE SHEET  
FORMING MACHINE



A COMPANY OF

**GEA** engineering for  
a better world

## High-speed and quick die change

The new MRD540 is a high-speed forming machine with quick die change. Is suitable for the production of single sheet ravioli, fagottini and cappelletti with hard and soft fillings.

It could be combined with different filling pumps: lobe, paddle and screw.

### Technical features:

- completely washable
- quick die change in 5 min
- ergonomic design and compact dimensions, to facilitate the use and the cleaning operations
- direct transmission controlled by engines with inverters
- removable scrap grinding unit
- conveyor belt for the sheet
- filling diffuser with compensating pistons
- two pairs of calibrating rolls
- Stainless steel electric panel installed on the machine



MRD with screw pump

### Dimensions:

Width  
1230 mm

Length  
1400 mm

Overall height  
1700 mm

Sheet inlet height  
1300 mm

# CAPACITY AND PRODUCTS

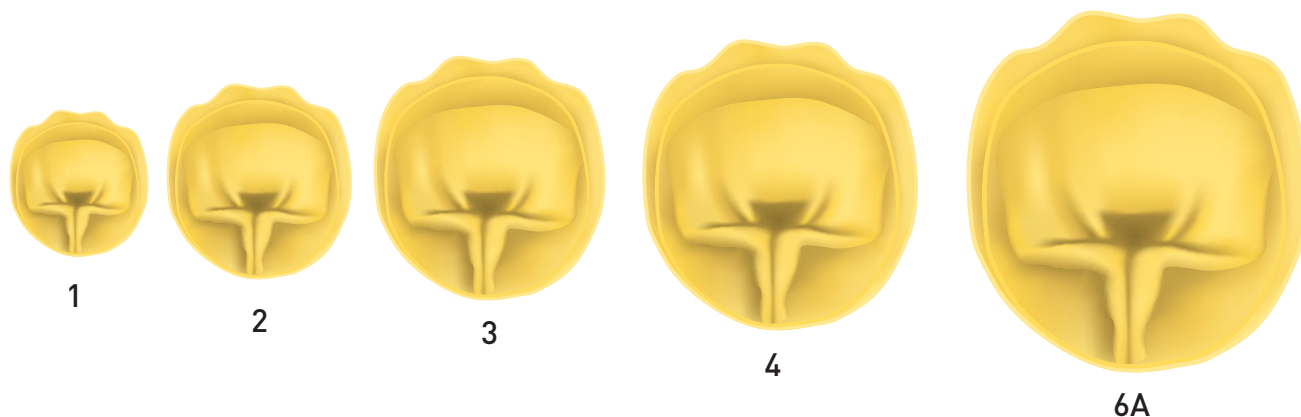

Classic      Type A      Type B      Type D      Type H

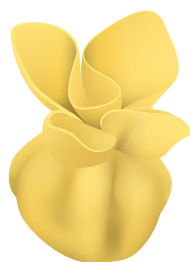
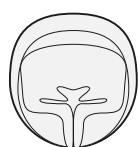
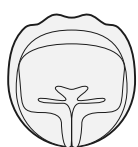

S50

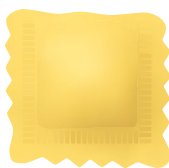

22x22

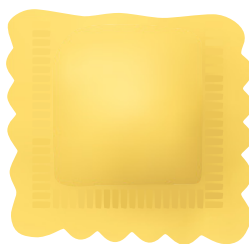

11B

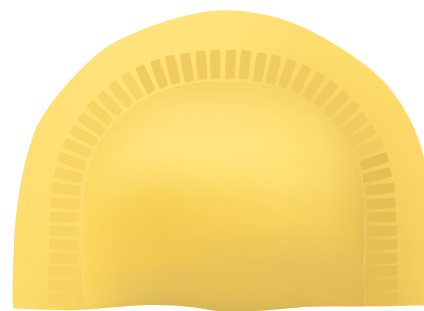

Pelmeni

Die #	Weight gr	Filling %	Pasta th. mm	Punches p	Speed strokes/min	Capacity Kg/h
1	2,4	30	1,00	10	180	259
2	3,3	33	0,95	10	180	356
3	8,0	37	1,10	7	150	504
4	14,0	45	1,20	5	120	504
6	22,0	45	1,20	4	100	528
S50	5,0	35	1,00	6	150	270
22x22	2,0	35	1,15	16	180	345
11B	4,3	37	1,10	12	180	557
Pelmeni	7,1	33	1,00	8	180	613

# FILLING PUMPS

---

## LOBE PUMP

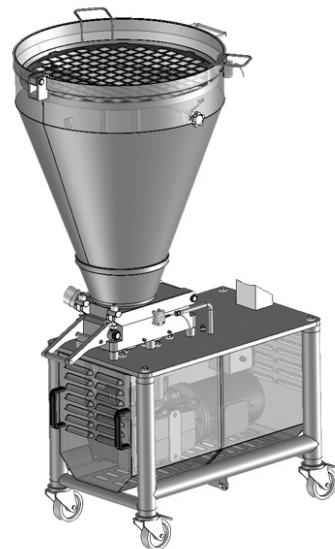

## PADDLE PUMP

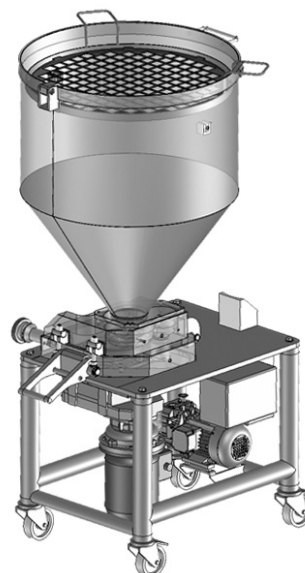

## SCREW PUMP

